

MODEL YK32

FULL PORT
#300
12"

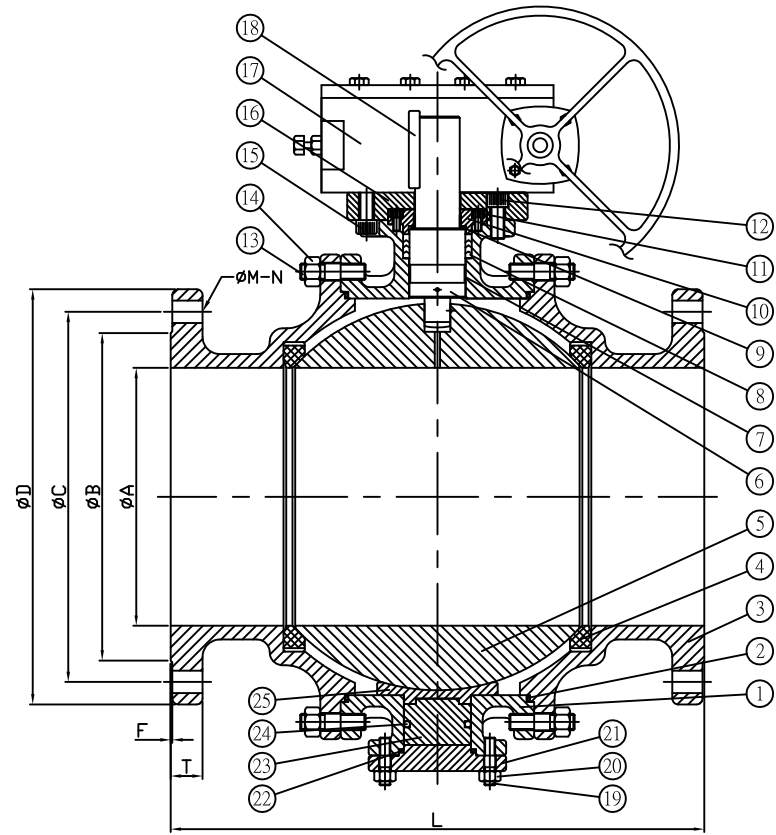
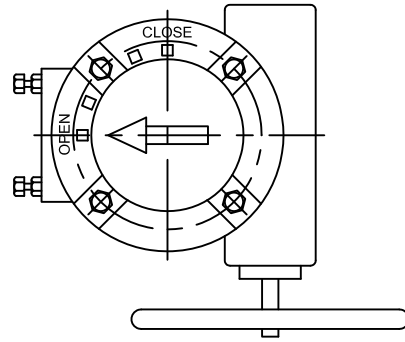

MATERIALS

NO.	PART NAME	MATERIAL
1	BODY	A351 CF8M/A216 WCB
2	GASKET	PTFE.
3	CAP	A351 CF8M/A216 WCB
4	SEAT	PTFE+15%G.F
5	BALL	ASTM A351 CF8M
6	STEM	S.S.316
7	STEM BUSHING	PTFE.
8	STEM PACKING	PTFE.
9	GLAND BEARING	PTFE.
10	GLAND	S.S.304
11	GLAND BOLT	S.S.304
12	GEAR BUCKET BOLT	S.S.304
13	BOLT	S.S.304
14	NUT	S.S.304
15	GEAR BOLT	S.S.304
16	GEAR BUCKET	S.S.304
17	GEAR BOX	CAST IRON
18	STEM PIN	S.S.304
19	BOLT	S.S.304
20	NUT	S.S.304
21	END PLATE	S.S.316
22	GASKET	PTFE.
23	BOTTOM STEM	S.S.316
24	O-RING	NBR
25	BOTTOM WASHER	PTFE+15%G.F

DIMENSIONS

Unit:Inch

SIZE	A	B	C	D	F	L	T	$\phi M-N$
12"	11.81	15.00	17.75	20.50	0.06	25.51	2.00	$\phi 1.25-16$

3PC FLANGE BALL VALVE ANSI #300LB 12"

DATE

2015/08/31

4
3
2
1

DIM.	0.5	3	6	30	120	315	MATERIAL
	3	6	30	120	315	1000	
CLASS 1	0.05	0.05	0.1	0.15	0.2	0.3	WEIGHT(Kg)
CLASS 2	0.1	0.1	0.2	0.3	0.5	0.8	SCALE
CLASS 3	0.15	0.2	0.5	0.8	1.2	2	DRAWING NO.

DRAWN
CHECK
APPROVED
J & M INTERNATIONAL LTD.

NO DATE DESCRIPTION CONFIRM

CLASS 3 0.15 0.2 0.5 0.8 1.2 2 DRAWING NO. YK32-300A-300LB