

MODEL YK32

FULL PORT
#300
1/2"-6"

TOP VIEW

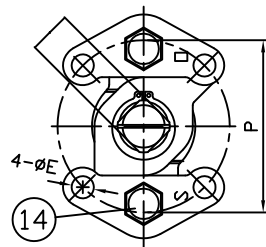

ISO 5211
MOUNTING PAD

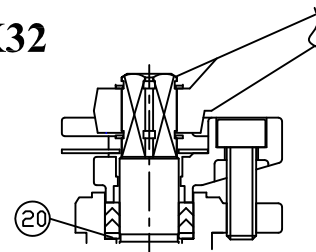

* 1/2"~1-1/4"

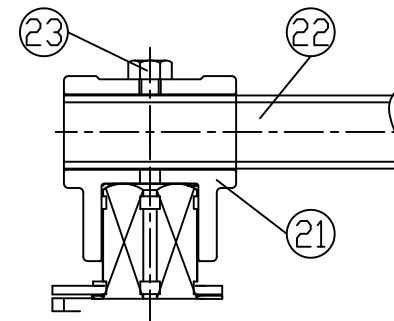

5"~6"

MATERIAL LIST

NO.	PART NAME	SPECIFICATION
1	BODY	A351-CF8M A216-WCB
2	CAP	A351-CF8M A216-WCB
3	BALL	ASTM A351 CF8M
4	STEM	S.S. 316
5	SEATS	PTFE+15%EKONDOL
6	GASKET	PTFE+15%EKONDOL
7	STEM PACKING	PTFE
8	THRUST WASHER	PTFE+15%G.F.
9	O-RING	FKM
10	GLAND FLANGE	ASTM A351 CF8
11	HANDLE	WCB (1/2"-4")
12	STOP PLATE	S.S.304
13	SNAP RING	S.S.304
14	GLAND BOLT	S.S. 304
15	BOLT	S.S. 304
16	NUT	S.S. 304
17	GLAND NUT	S.S. 304
18	GLAND BUSH	PTFE
19	STATIC SPRING	S.S.316
20	WASHER	S.S. 304
21	HANDLE HEAD	ASTM A351 CF8
22	HANDLE BAR	CARBON STEEL
23	HANDLE BOLT	S.S. 304

DIMENSION LIST (ANSI #300)

UNIT:(inch)

TYPE SIZE	Ød	L	H	H1	D1	P	ØE	W	D	C	T	Øh-N
1/2"	0.59	5.51	3.23	0.3	5.11	1.65	0.24	0.35	3.74	2.62	0.56	0.63-4
3/4"	0.79	5.98	3.35	0.3	5.11	1.65	0.24	0.35	4.61	3.25	0.63	0.75-4
1"	0.98	6.50	3.70	0.34	6.30	1.97	0.28	0.43	4.88	3.50	0.69	0.75-4
1-1/2"	1.57	7.48	4.53	0.61	9.06	2.76	0.35	0.67	6.14	4.51	0.81	0.87-4
2"	1.97	8.50	4.72	0.64	9.06	2.76	0.35	0.67	6.50	5.00	0.88	0.75-8
2-1/2"	2.56	9.49	6.10	0.86	15.75	4.02	0.43	0.87	7.48	5.87	1.00	0.87-8
3"	3.15	11.14	6.50	0.86	15.75	4.02	0.43	0.87	8.27	6.61	1.13	0.87-8
4"	3.94	12.01	7.87	0.86	17.71	4.02	0.43	1.06	10.00	7.87	1.25	0.87-8
5"	4.92	15.00	9.84	0.85	29.53	4.92	0.51	1.06	11.00	9.25	1.38	0.87-8
6"	5.91	15.87	11.89	0.85	29.53	4.92	0.51	1.06	12.52	10.63	1.44	0.87-12

**SUITABLE USE FOR NATURAL GAS (2ND STAGE ONLY)

2PC FLANGE BALL VALVE ANSI #300LB 1/2"~6"										DATE	2015/08/31						
NO	DATE	DESCRIPTION	CONFIRM	DIM.	0.5	3	6	30	120	315	MATERIAL	CF8M/WCB	DRAWN				
				CLASS	3	6	30	120	315	TREATMENT				CHECK			
				CLASS 1	0.05	0.05	0.1	0.15	0.2						0.3	WEIGHT(Kg)	APPROVED
				CLASS 2	0.1	0.1	0.2	0.3	0.5						0.8		
CLASS 3	0.15	0.2	0.5	0.8	1.2	2	DRAWING NO.	YK32#300LB									