

MODEL YK321FS

CARBON STEEL, ANSI 150LB
 FIRE SAFE APPROVED
 W/ISO 5211 MOUNTING PAD
 W/HANDLE 1/2"~6"

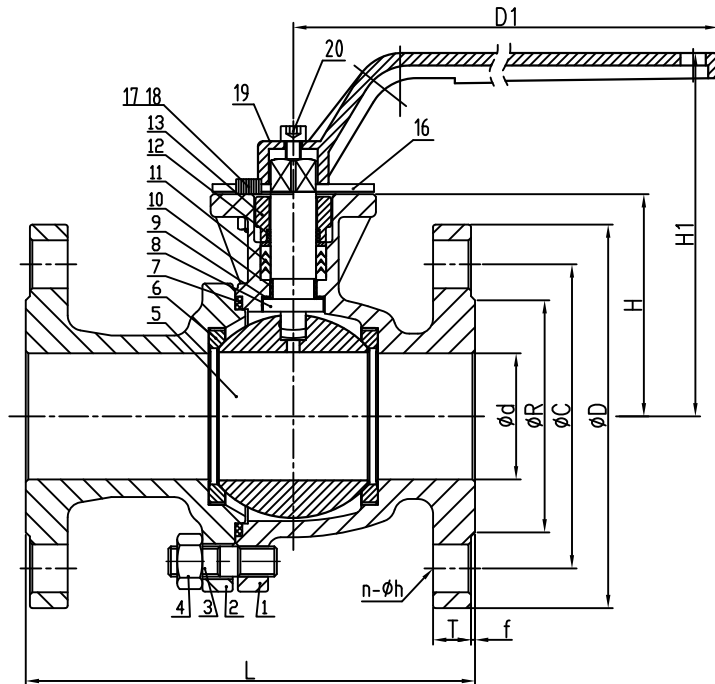
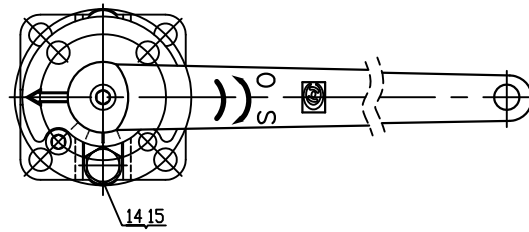

Size Table: Unit (inch)

SIZE	d	H	L	R	C	D	T	f	H1	D1	n-φh
1/2"	0.59	2.11	4.25	1.38	2.38	3.50	0.43	0.06	3.66	4.53	4-φ0.63
3/4"	0.79	2.11	4.61	1.69	2.76	3.86	0.47	0.06	3.66	4.53	4-φ0.63
1"	0.98	2.48	5.00	2.01	3.13	4.25	0.51	0.06	4.41	5.71	4-φ0.63
1 1/4"	1.26	2.66	5.51	2.52	3.50	4.61	0.57	0.06	4.61	5.71	4-φ0.63
1 1/2"	1.57	3.16	6.50	2.87	3.88	5.00	0.57	0.06	5.39	8.66	4-φ0.63
2"	1.97	3.46	7.01	3.62	4.74	5.98	0.59	0.06	5.67	8.66	4-φ0.75
2 1/2"	2.56	4.29	7.48	4.13	5.49	7.01	0.65	0.06	6.69	12.60	4-φ0.75
3"	3.15	4.72	7.99	5.00	6.00	7.48	0.71	0.06	7.13	12.60	4-φ0.75
4"	3.94	5.97	9.02	6.18	7.50	9.02	0.88	0.06	8.58	16.93	8-φ0.75
5"	4.92	6.68	14.02	7.32	8.50	10.00	0.88	0.06	9.29	16.93	8-φ0.88
6"	5.91	8.15	15.51	8.50	9.51	10.98	0.94	0.06	11.34	29.53	8-φ0.88

APPLICABLE STANDARDS

Design: ASME B16.34
 Pressure Rating: CLASS 150
 Face to Face: ASME B16.10
 End Flange: ASME B16.5
 Inspection & Testing: API598
 Hydrostatic Shell Test: 30bar
 Pneumatic Seat Test: 4-7bar

NO		PARTS NAME	Q'TY	MTR			REMARKS
20	/	HANDLE BOLT	1	A193-B8			
19	/	HANDLE	1	WCB			
18	/	NUT	1	A194-8			
17	/	BOLT	1	A193-B8			
16	/	STOP PLATE	1	304			
15	/	GLAND NUT	2	A194-8			
14	/	GLAND BOLT	2	A193-B8			
13	/	GLAND FLANGE	1	CF8			
12	/	GLAND BEARING	1	PTFE			
11	/	PACKING	/	GRAPHITE			
10	/	STEM BEARING	1	PTFE			
9	/	THRUST WASHER	1	PTFE			
8	/	STEM	1	SUS316			
7	/	GASKET	1	SPW316+Graphite			
6	/	SEAT	2	PTFE			
5	/	BALL	1	CF8M			
4	/	CAP BOLT NUT	/	A194-8			
3	/	CAP BOLT	/	A193-B8			
2	/	CAP	1	WCB			
1	/	BODY	1	WCB			

				2-Pc Flanged B/V, 150# w/ Direct Mounting Pad, Fire Safe Approved			ASSEMBLY DRAWING	
							J&M INTERNATIONAL LTD.	
							BR-M2F(WCB).dwg	
MARK	QTY	DESCRIPTION	SIGNATURE	DATE	Project	Mark	Weight	Scale
Drawn		L.Ma						
Proofreader								1:2
Check		Y.J.Wang						
Technology			Date	2013.9.12	Total Paper		PageNo	