

MODEL YK524

FULL BORE
1000 WOG
1/4"-2"

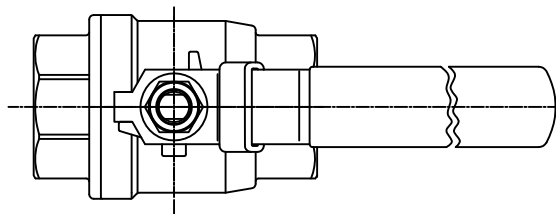

■ DIMENSIONS(INCH) [△]

SIZE	∅D	E	H	L
1/4"	0.46	4.04	1.97	1.97
3/8"	0.49	4.04	1.97	1.97
1/2"	0.59	5.24	2.28	2.36
3/4"	0.79	5.24	2.32	2.76
1"	0.98	6.02	2.72	3.15
1 1/4"	1.26	6.02	2.95	3.74
1 1/2"	1.5	7.52	3.27	4.09
2"	1.97	7.52	3.58	4.88

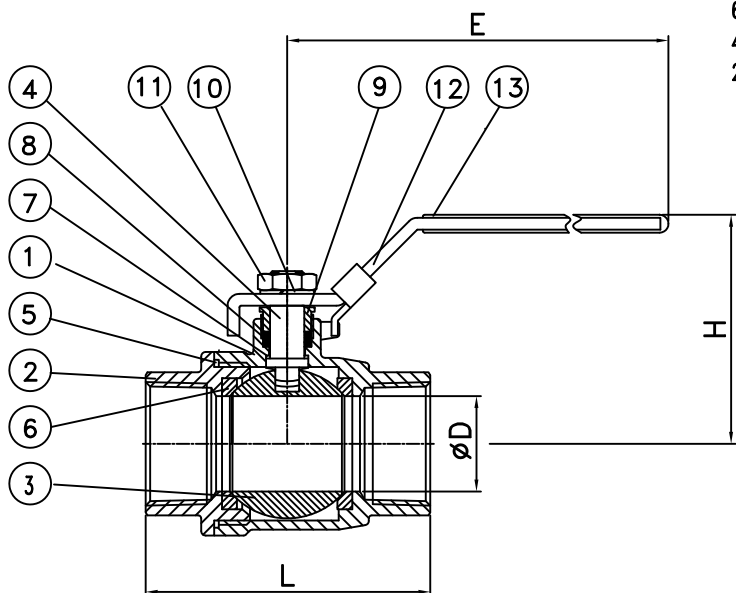
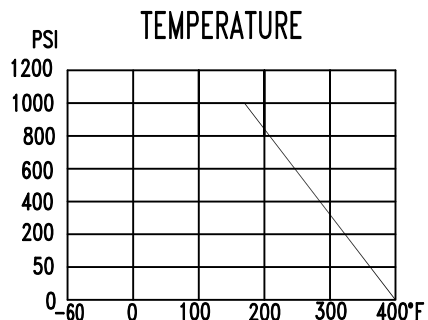

■ MATERIALS LIST

NO.	PART NAME	Q'TY	MATERIAL
1	BODY	1	ASTM-A216-WCB
2	BODY CAP	1	ASTM-A216-WCB
3	BALL	1	ASTM-CF8M-A351
4	STEM	1	SS 316
5	BODY SEAT	1	PTFE
6	SEAT	2	PTFE
7	THRUST WASHER	1	PTFE
8	PACKING	1	PTFE
9	GLAND NUT	1	SS 304
10	STEM WASHER	1	SS 304
11	STEM NUT	1	SS 304
12	HANDLE	1	SS 304
13	COVER	1	PLASTIC

修正 REVISION	日期 DATE	說明 DESCRIPTION	繪圖 DRAWN BY	設計 DESIGNED BY	比例尺 SCALE
△	98-02-11	1/2"-2" 長度修改	PETER	PETER	
			核對 CHECKED BY	核 准 APPROVAL BY	日 期 DATE
					95-08-24

J&M INTERNATIONAL LTD

MODEL YK524

圖 號
DRAWING NO.

202WCB