

# MODEL YK-14DM

## 1000 WOG, REDUCE PORT L-PORT

### MATERIALS LIST

NO.	PART NAME	SPECIFICATION	Q'TY
1	BODY	ASTM A351 CF8M	1
2	END CAPS	ASTM A351 CF8M	3
3	BLIND CAP	ASTM A351 CF8M	1
4	BALL	ASTM A351 CF8M	1
5	STEM	S.S.316	1
6	SEATS	PTFE	4
7	GASKET-1	PTFE	3
8	GASKET-2	PTFE	1
9	STEM PACKING-1	PTFE+15%C.F.	1
10	STEM PACKING-2	TFM1600	1
11	STEM PACKING-3	TFM1600	1
12	DISC SPRING	SUS304CSP	2
13	SNAP RING	S.S.304	1
14	O-RING	VITON	1
15	HANDLE	CF8	1
16	HANDLE BOLT	S.S.304	1
17	STOPPER	S.S.304	1
18	STOP BOLT&NUT	S.S.304	1

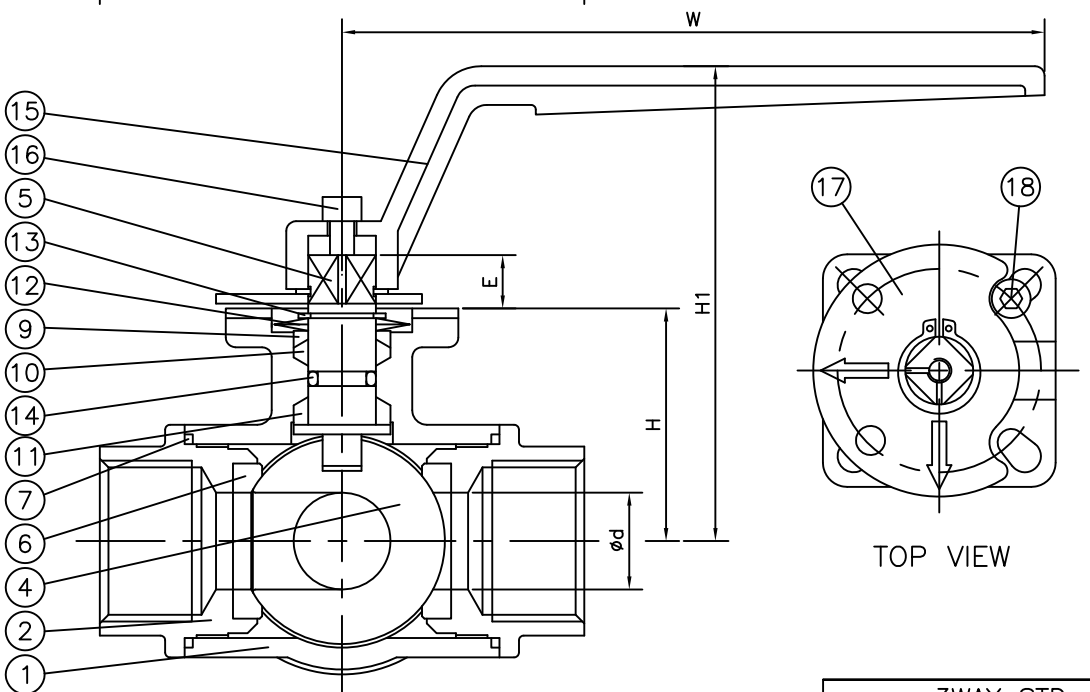
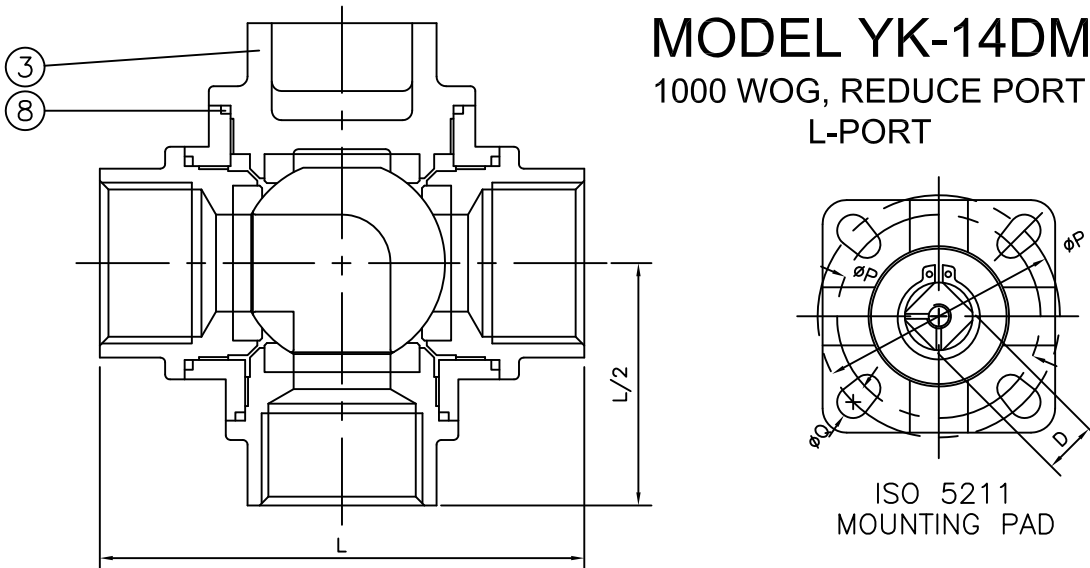

### DIMENSIONS

UNIT:(Inch)

TYPE SIZE	ød	L	H	D	E	W	H1	ISO 5211	
								P	Q
1/4"	0.44	2.95	1.56	0.35	0.31	4.53	3.15	F03/F04	
								1.42/1.65	ø0.24
3/8"	0.50	2.95	1.56	0.35	0.31	4.53	3.15	F03/F04	
								1.42/1.65	ø0.24
1/2"	0.50	2.95	1.56	0.35	0.31	4.53	3.15	F03/F04	
								1.42/1.65	ø0.24
3/4"	0.63	3.35	1.69	0.35	0.31	4.53	3.31	F03/F04	
								1.42/1.65	ø0.24
1"	0.79	3.94	1.87	0.43	0.43	5.71	3.86	F04/F05	
								1.65/1.97	ø0.24/ø0.28
1-1/4"	0.98	4.53	2.09	0.43	0.43	5.71	4.06	F04/F05	
								1.65/1.97	ø0.24/ø0.28
1-1/2"	1.26	4.96	2.42	0.55	0.55	8.66	4.69	F05/F07	
								1.97/2.76	ø0.28/ø0.35
2"	1.50	5.83	2.78	0.55	0.55	8.66	5.04	F05/F07	
								1.97/2.76	ø0.28/ø0.35

3WAY STD. PORT 1000WOG THREADED B.V. (LPORT)

DATE 2006/4/11

DIM.	0.5 3	3 6	6 30	30 120	315 1000	MATERIAL	CF8M	DRAWN
4								
3								
2								
1								
NO	DATE	DESCRIPTION	CONFIRM	CLASS 1	CLASS 2	CLASS 3	SCALE	J&M INTERNATIONAL LTD.
				0.05	0.1	0.15	1:1	
				0.05	0.1	0.2	DRAWING NO.	YK-LTM-B