

MODEL YK33

FULL PORT

#150

1"-6"

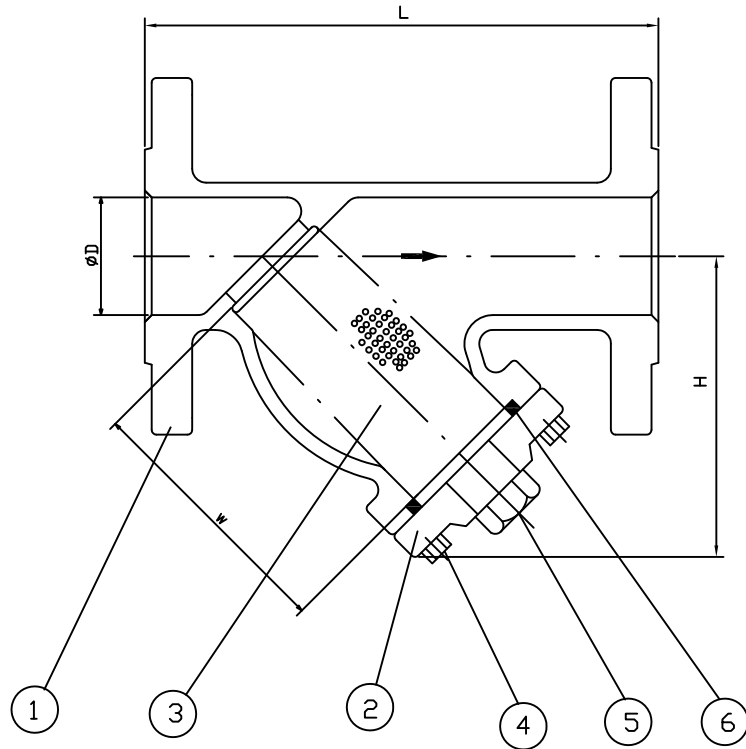

MATERIAL LIST

NO.	PARTS	MATERIAL
1	BODY	A351-CF8M
2	COVER	A351-CF8M
3	SCREEN	S.S. 316
4	BOLT	S.S. 304
5	PLUG	A351-CF8M
6	GASKET	PTFE

DIMENSIONS

UNIT:(Inch)

size	ØD	L	H	W	PLUG NPT	Std Mesh
1"	0.98	7.36	4.06	3.75	1/4"	1/32"perf
1-1/2"	1.5	7.24	4.72	4.31	1/2"	1/32"perf
2"	2	8.62	4.88	4.56	1/2"	3/64"perf
3"	3	11.61	7.76	6.62	1"	3/64"perf
4"	3.87	14.25	9.13	7.80	1-1/2"	1/8"perf
6"	6	18.62	13.39	11.69	2"	1/8"perf

Y-STRAINER FLANGED #150LB ASSEMBLY DRAWING

NO	DATE	DESCRIPTION	CONFIRM	Y-STRAINER FLANGED #150LB ASSEMBLY DRAWING								DATE	2004.10.17			
④				JIS B0403	CASTING DIM.	-- 10	10~16	16~25	25~40	40~63	63~100	100~160	MATERIAL	CF8M	DRAWN	Y.S.W.
③													CT6	±0.52	±0.54	±0.58
②				JIS B0405	MACHINE DIM.	-- 3	3~6	6~30	30~120	120~315	315~1000	1000~2000	WEIGHT(Kg)		APPROVED	
①													CLASS14	±0.1	±0.1	±0.2
													DRAWING NO.	YK33	J & M INTERNATIONAL LTD.	