

MODEL YK5210

REDUCED BORE
1/4"-2" 2000WOG

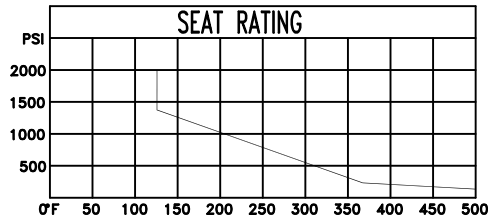

■ MATERIALS LIST

NO.	PART NAME	Q'TY	MATERIAL
1	BODY	1	CF8M
2	END CAP	1	CF8M
3	BALL	1	SS316
4	STEM	1	SS316
5	BODY SEAL	1	PTFE
6	SEAT	2	TFM1600
7	STEM SEAL	1	PTFE
8	STEM PACKING	1	PTFE
9	GLAND NUT	1	SS304
10	SPRING	1	STEEL
11	BOLT	1	STEEL
12	HANDLE	1	SS304
13	HANDLE SLEEVE	1	VINYL
14	STOPPER BOLT	1	SS304

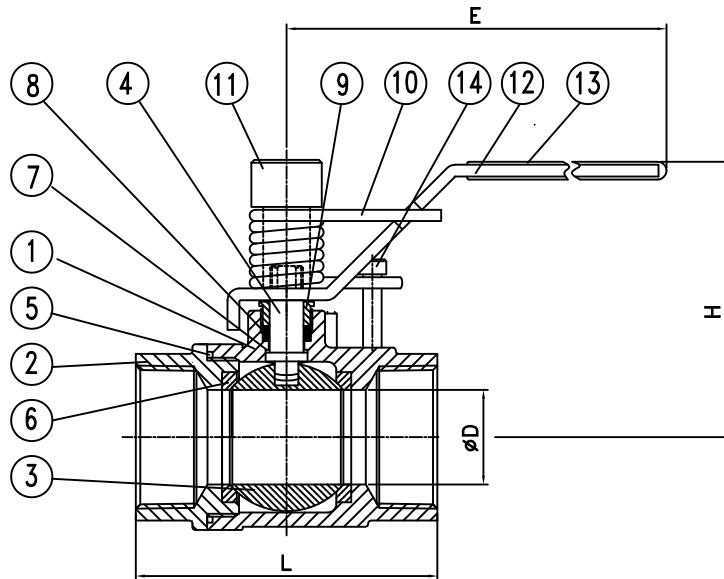

■ DIMENSIONS(INCH)

SIZE	Ø D	E	H	L	G1	G2
1/4"	0.37	4.65	2.28	2.05	1.1	0.5
3/8"	0.37	4.65	2.28	2.05	1.1	0.5
1/2"	0.5	4.65	2.4	2.44	1.1	0.5
3/4"	0.59	5.43	2.76	2.72	1.38	0.88
1"	0.79	5.43	2.87	3.31	1.38	0.88
1 1/4"	0.98	7.05	3.41	3.54	1.5	1.0
1 1/2"	1.26	7.05	3.6	4.09	1.5	1.0
2"	1.5	8.5	4.13	4.61	1.5	1.0

REVISION	DATE	DESCRIPTION	DRAWN BY PETER	DESIGNED BY PETER	SCALE	J&M INTERNATIONAL LTD	MODEL YK5210	DRAWING NO.
			CHECKED BY	APPROVAL BY	DATE 91-05-20			